



Eyal Microwave Ltd.

Phone: 972-9-7499100 Fax: 972-9-7493669

Kibbutz Eyal D.N. Hasharon Hatichon 45840 Israel

Web: www.eyal-emi.com Email: emi@eyal-emi.com



Specification For

6 to 18 GHz

De Modulator

MODEL: DMOD-2350-09

Item Definition and General Description

The De-Modulator Module is a dual channel, broadband, 6 GHz to 18 GHz inputs, 70 \pm 20 MHz outputs unit.

Its major function is to mix two RF signals separated 70 \pm 20 MHz apart producing a 70 \pm 20 MHz signal.

Each channel is composed of an Image Reject Mixer (IRM). A common local RF signal feeds both channels.



Eyal Microwave Ltd.

Phone: 972-9-7499100 Fax: 972-9-7493669

Kibbutz Eyal D.N. Hasharon Hatichon 45840 Israel

Web: www.eyal-emi.com Email: emi@eyal-emi.com



BLOCK DIAGRAM

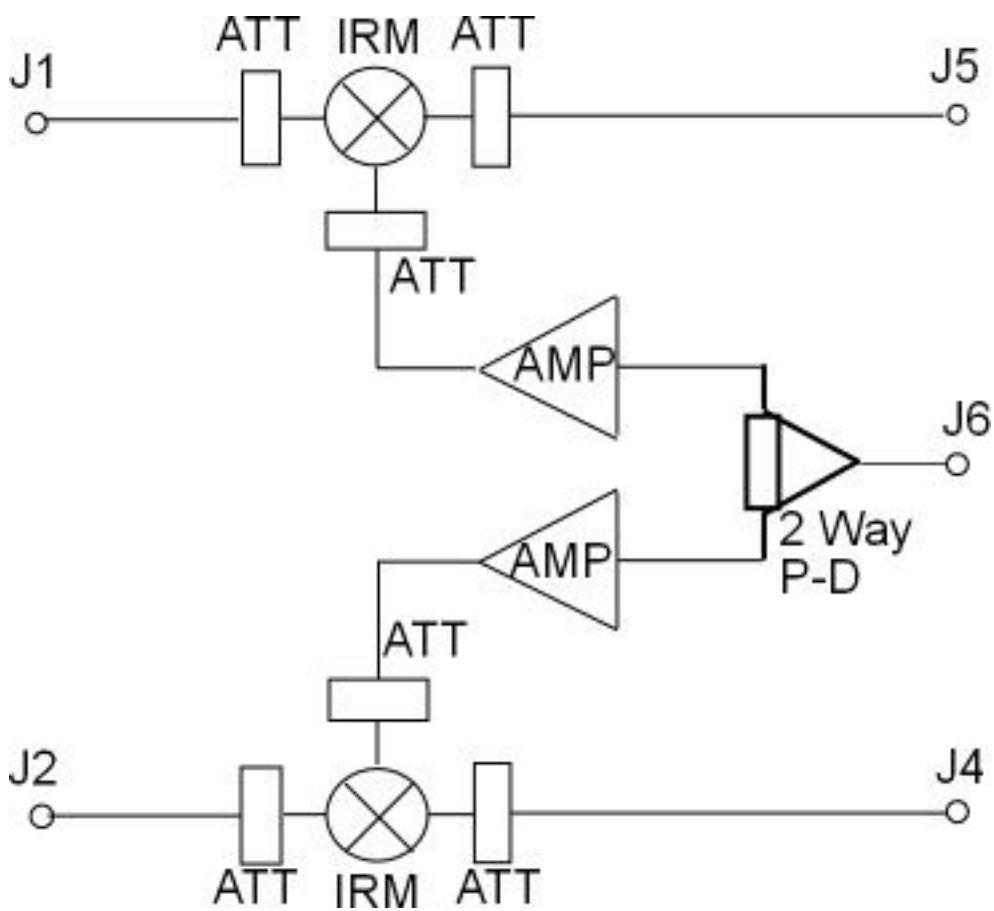



Eyal Microwave Ltd.

Phone: 972-9-7499100 Fax: 972-9-7493669

Kibbutz Eyal D.N. Hasharon Hatichon 45840 Israel

Web: www.eyal-emi.com Email: emi@eyal-emi.com



Electrical Specification

All specifications assume the application of LO signal to J6 with +7 dBm powers.

Frequency Range (J1, J2, J6):.....6.0÷18.0 GHz

Frequency Range (J4, J5):

The frequency range for full small-signal up to the 1 dB compression point: 70±20 MHz.

(Gain Best-Fit Line - G.B.F.L.)

Gain Limits:

For RF path J1 to J5:

G.B.F.L @ 6 GHz:..... -12.0dB ±1.0 dB

For RF path J2 to J4:

G.B.F.L @ 6 GHz..... -12.0dB ±1.0 dB

Gain flatness:

For RF path J1 to J5:..... ±1.5 dB over full freq. range.

For RF path J2 to J4: ±1.5 dB over full freq. range.

Input Power @ 1 dB Compression Point (either J1 or J2):..... + 11 dBm min.

Upper Sideband Rejection

Better than 15 dBc (below the desired lower sideband power).

LO Leakage

The power measured at J4 or J5, when a +7 dBm signal is applied to J6, J1&J2 are terminated, shall be less than..... -7 dBm.

The power measured at J1 or J2, when a +7 dBm signal is applied to J6, J4&J5 are terminated, shall be less than..... -4 dBm.

Isolation between Channels

For J1 when J4 terminated: -70 dB min.

For J1 terminated J4 open circuit: -60 dB min

For J1 open circuit, J4 terminated:..... -60 dB min



Eyal Microwave Ltd.

Phone: 972-9-7499100 Fax: 972-9-7493669

Kibbutz Eyal D.N. Hasharon Hatichon 45840 Israel

Web: www.eyal-emi.com Email: emi@eyal-emi.com



RETURN - LOSS.

Impedance (all ports): 50Ω

Return-Loss (all ports)< -12 dB.

Max Operating RF Input Power+12 dBm C. W.

DC Voltages & Currents +11 VDC ±10% 650mAmax.

Physical Characteristics and Connectors

The module packaged in hermetically sealed Aluminium case.

J1 and J2 RF connectors are GPO type (field replaceable to SMA).

J4, J5 & J6 RF SMA female connectors.

The DC and control are Solder Pins.

Size (mm): 70 X 50 X 15