

REV	DESCRIPTION	NAME	DATE
	INIT.	S.V	16/12/01

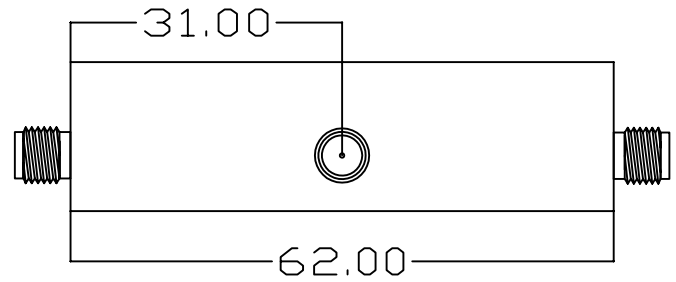
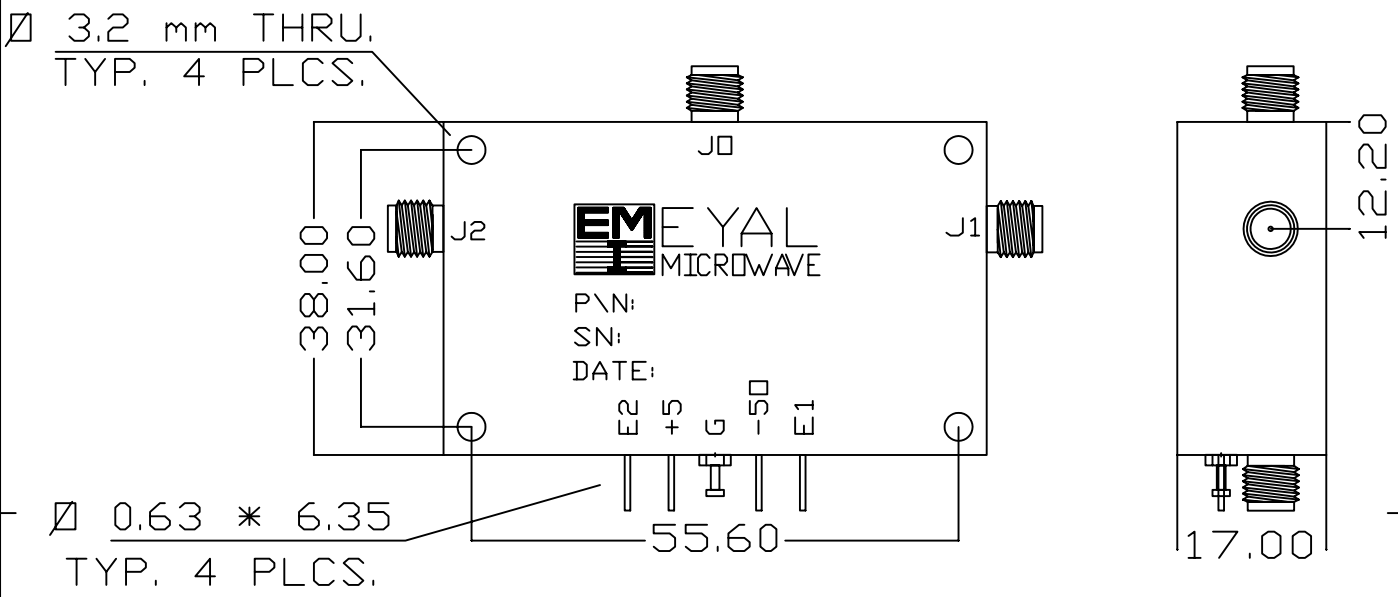
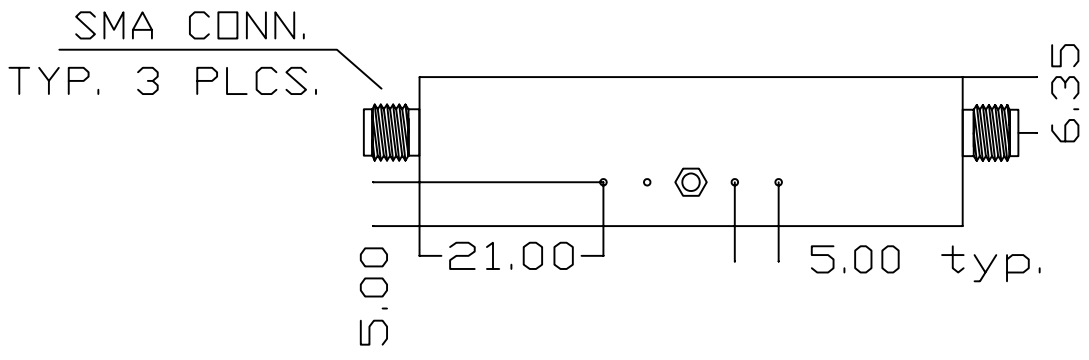

NEXT ASSEMBLY		FINISH	BLACK EPOXY	NAME	DATE
		PLATING PER		S.V	16/12/01
		PAINTING PER		M.D.	16/12/01
		MATERIAL	AL-6061-T6	M.C	16/12/01
		SUREFACE FINISH			
		GENERAL TOLERANCES	TITLE		
DIM	MM	.X ±.5	SPDT H.P SWITCH		
SCALE		MARKING - WHITE	DRAWING NO. 1278		REV.
EYAL MICROWAVE INDUSTRY					